

**RAISED PAVEMENT MARKING PLACEMENT PATTERNS**  
PLACED W/ REFLECTION PAVEMENT MARKERS (OPTIONAL)

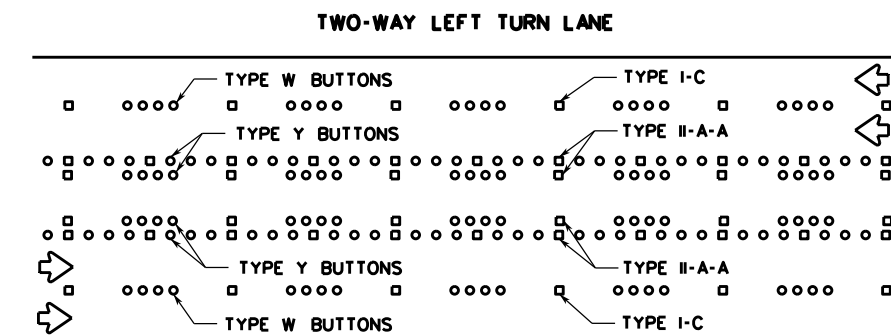

**RAISED PAVEMENT MARKINGS PLACEMENT DETAILS**  
PLACED W/ REFLECTION PAVEMENT MARKERS (OPTIONAL)

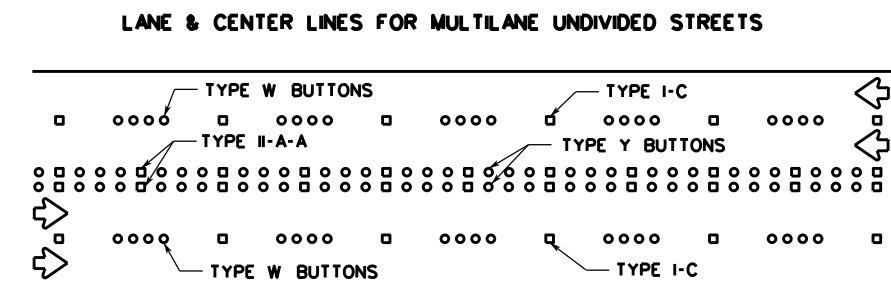
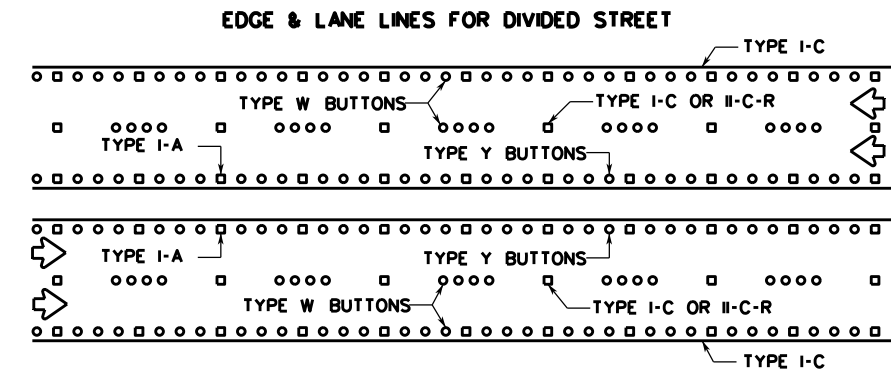
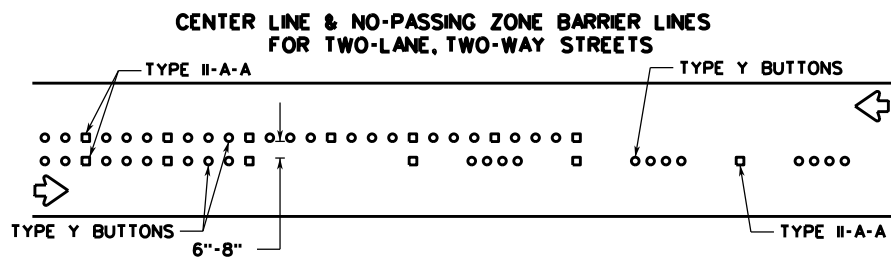
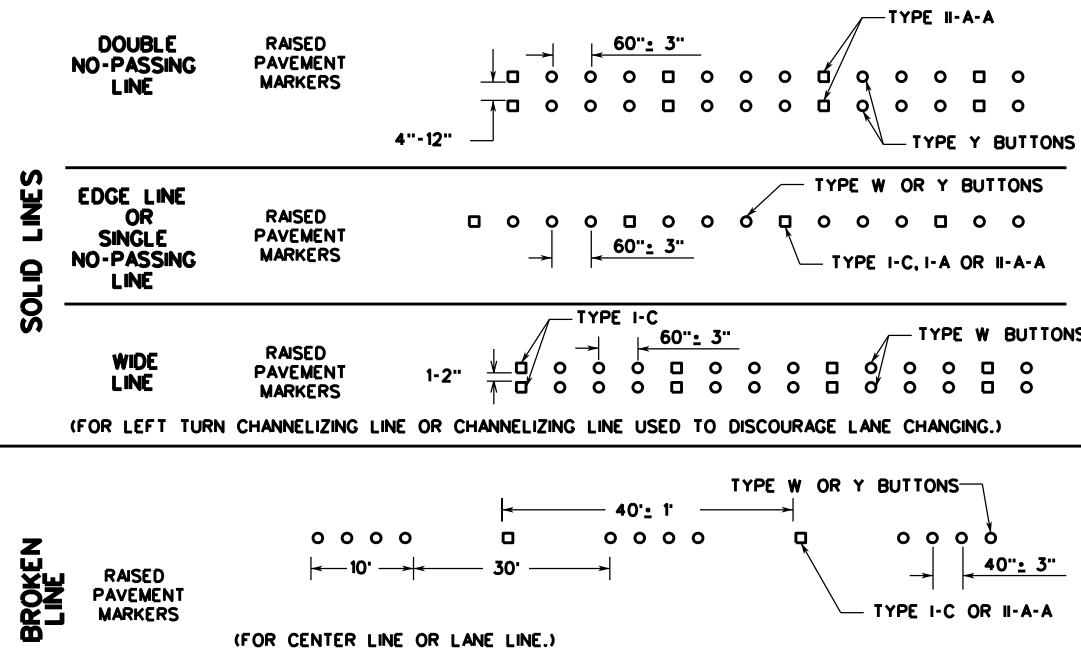

**TRAFFIC BUTTONS (NON-REFLECTORIZED)**

NOTE: MINIMUM AREA OF MARKERS SHALL BE NOT LESS THAN 12.5 SQUARE INCHES.

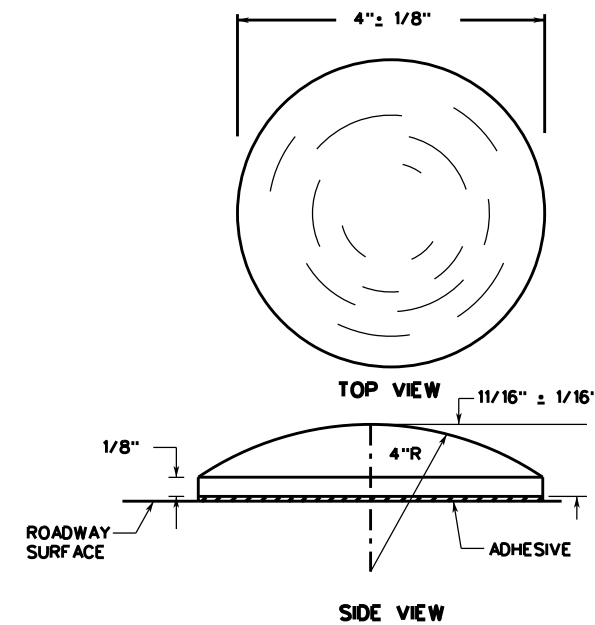

**JIGGLE BAR TILES (NON-REFLECTORIZED)**

"JIGGLE BARS" CONSIST OF A NUMBER OF JIGGLE BAR TILES PLACED IN A LINEAR CONFIGURATION.

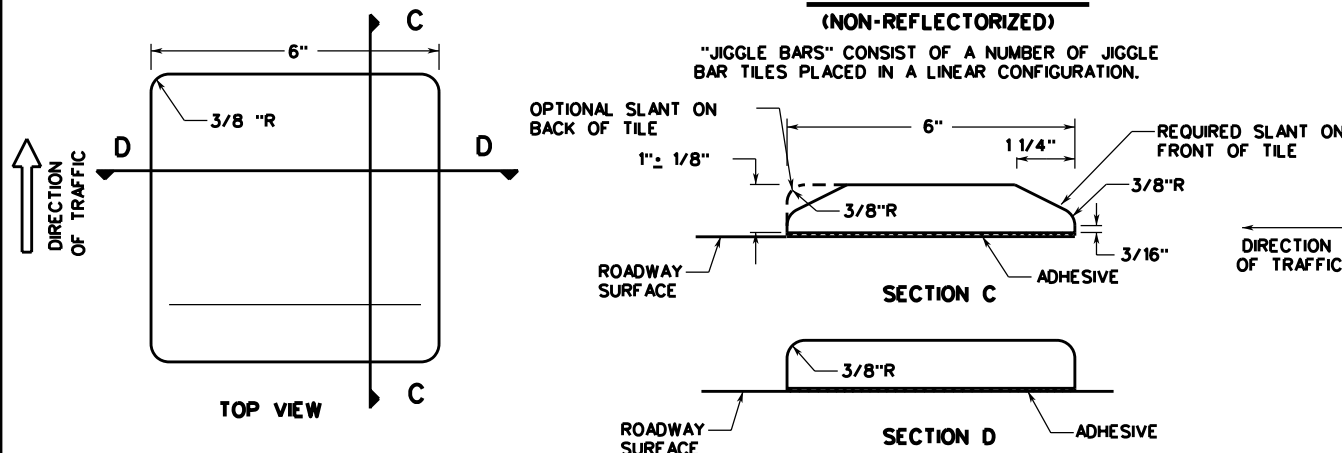

**NOTES:**

1. RAISED PAVEMENT MARKERS (RPMs) MAY CONSIST OF TRAFFIC BUTTONS, PAVEMENT MARKERS AND/OR JIGGLE BAR TILES. PAVEMENT SURFACE SHALL BE PREPARED AND CLEANED SUBJECT TO APPROVAL OF THE CITY TRAFFIC ENGINEER BEFORE ADHESIVE AND RPMs ARE PLACED.
2. JIGGLE BARS SHALL BE ORIENTED PERPENDICULAR TO ROADWAY. JIGGLE BARS SHALL ALSO BE PLACED AT SUCH OTHER LOCATIONS AS SHOWN IN PLANS OR AS DIRECTED BY THE CITY TRAFFIC ENGINEER.
3. MARKERS, BUTTONS AND JIGGLE BAR TILES SHOWN ARE FOR ILLUSTRATION PURPOSES ONLY AND NOT INTENDED TO SPECIFY ANY PARTICULAR PRODUCT. ALL PAVEMENT MARKERS PROVIDED SHALL BE OF THE SAME MANUFACTURER.
4. ALL DIMENSIONS ARE +/- 1/8" UNLESS OTHERWISE NOTED.
5. ALL PAVEMENT MARKING MATERIALS SHALL MEET MATERIAL SPECIFICATIONS AS SPECIFIED BY CITY OF SAN ANTONIO STANDARD SPECIFICATIONS.
6. TRAFFIC BUTTONS AND JIGGLE BAR TILES ARE TO BE USED ONLY FOR TEMPORARY TRAFFIC CONTROL OR AS DIRECTED BY THE CITY TRAFFIC ENGINEER.

**RAISED PAVEMENT MARKERS (REFLECTORIZED)**

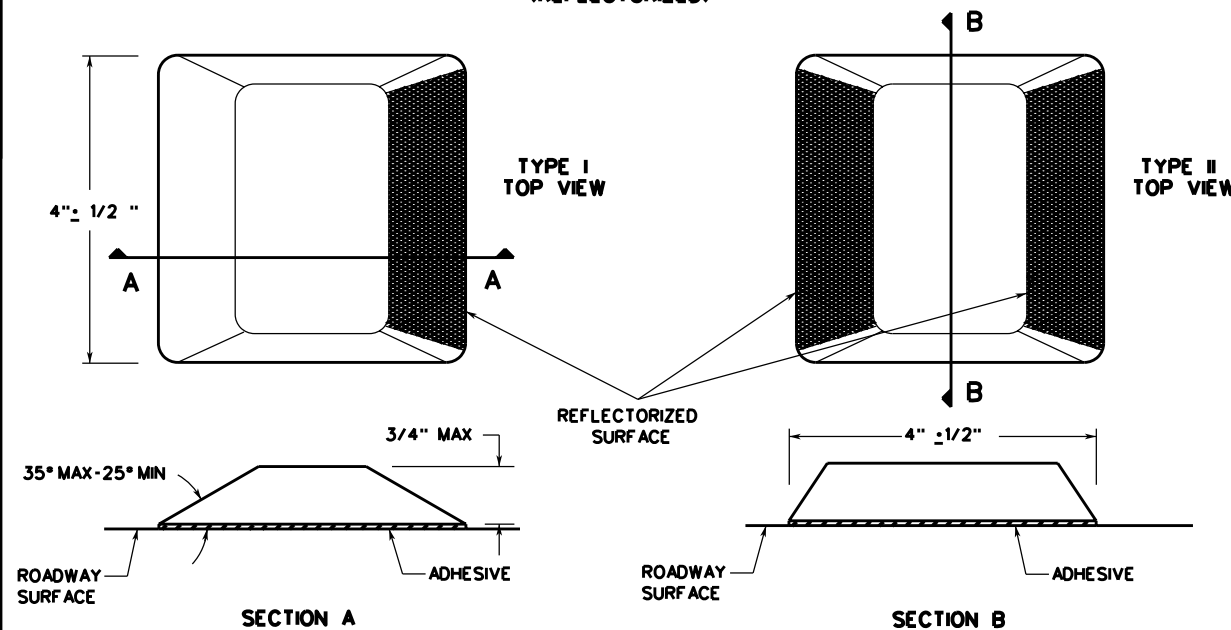

SEPTEMBER 2009

CITY OF SAN ANTONIO  
DEPARTMENT OF PUBLIC WORKS

TRAFFIC ENGINEERING STANDARDS  
RAISED PAVEMENT MARKERS, REFLECTIVE  
PAVEMENT MARKERS, TRAFFIC BUTTONS &  
JIGGLE BAR TILES 2  
SHEET 5 OF 16